

Top view

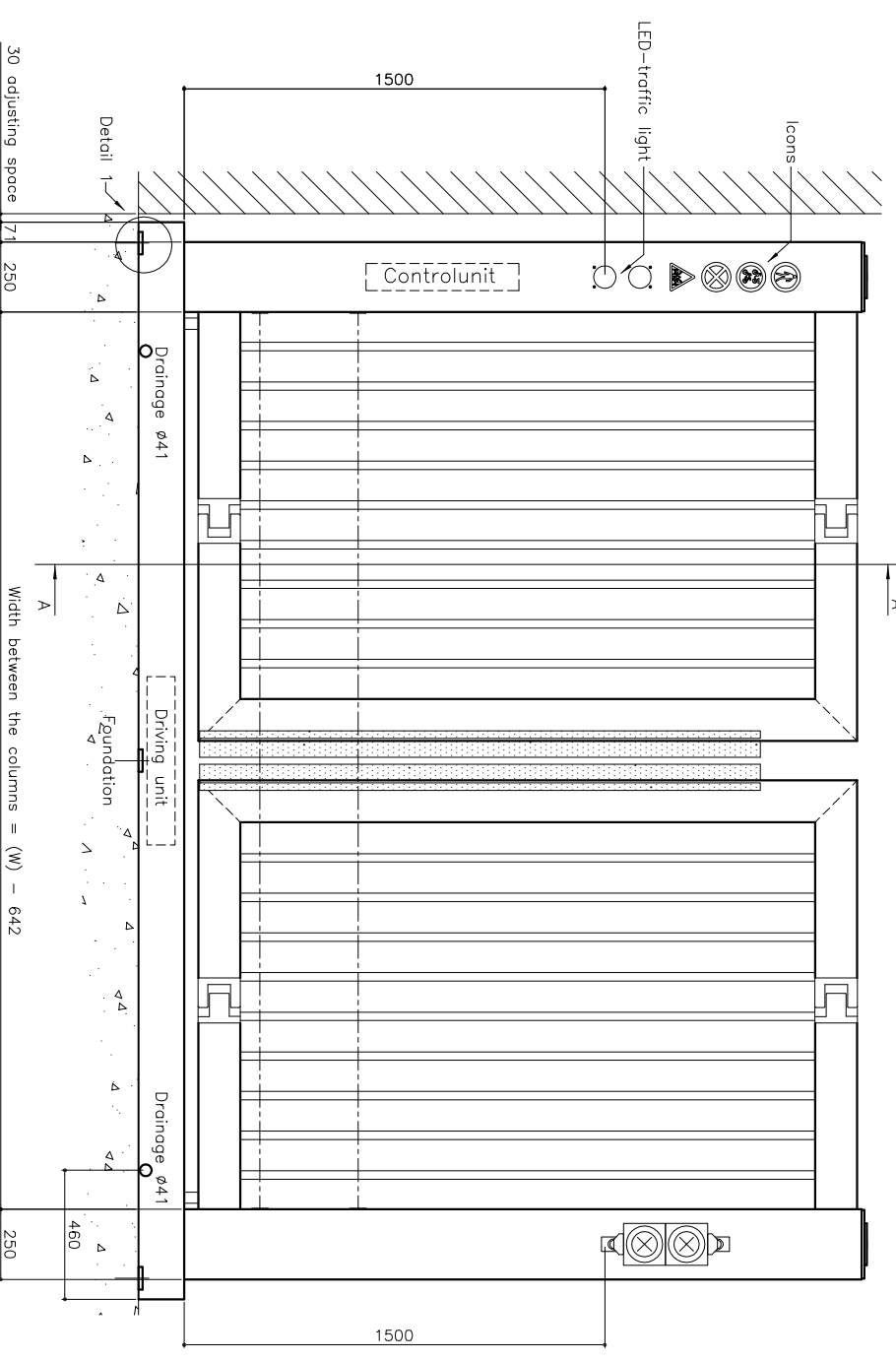

Front view

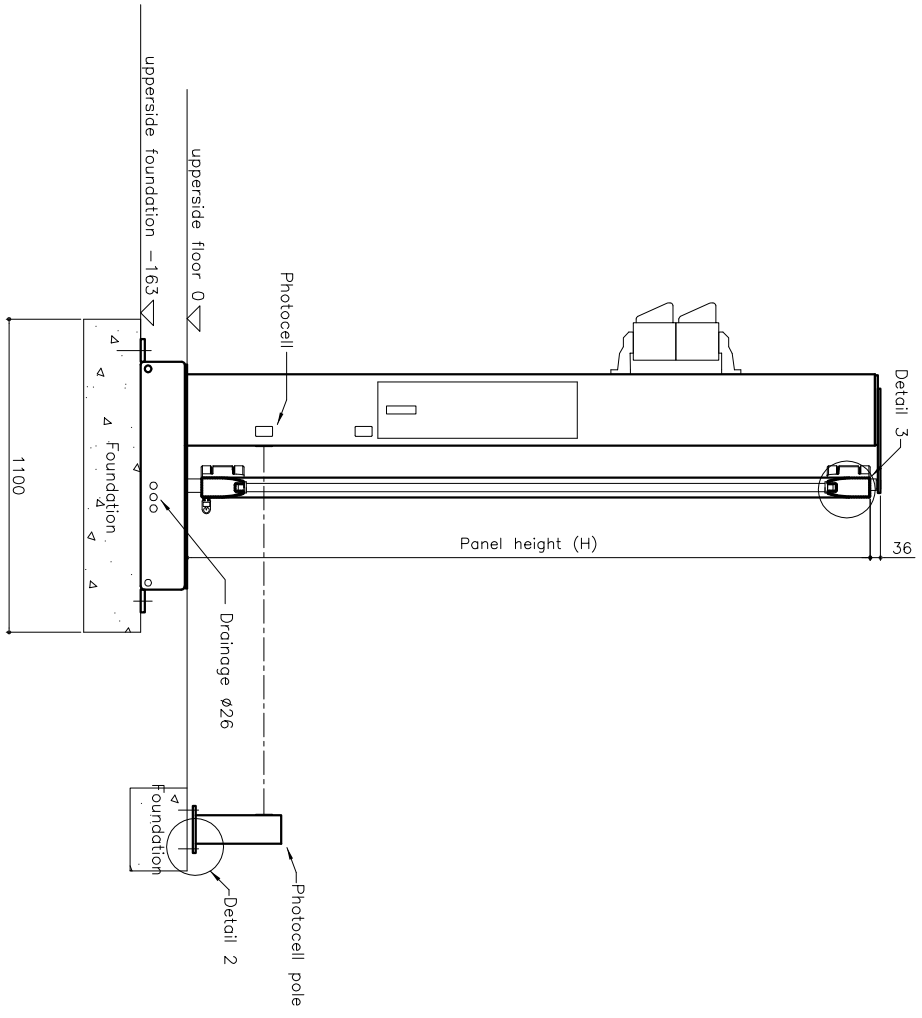

Section A-A

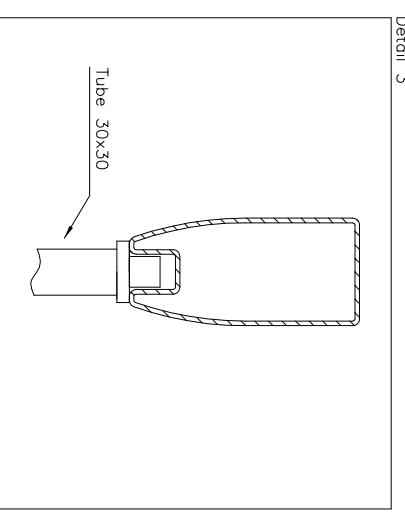
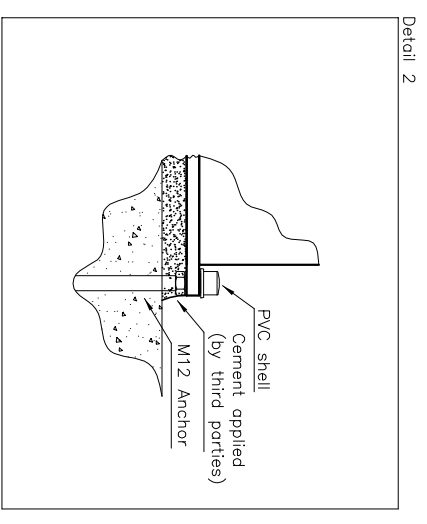
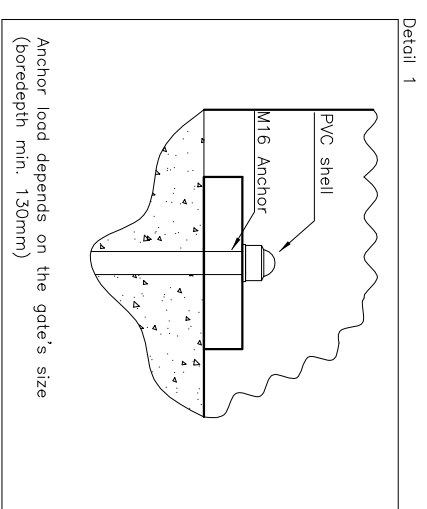

Comments:

- Only the main components are drawed
- Fundation equal and horizontal max ± 2mm
- Rainwater discharge apply by client
- Cable ducting needs to be applied by client according to cable plan

HOLLAND TRAFFIC CONTROL

INDUSTRIESTRAAT 13, MOERKAPELLE TEL.: 079-5933200 WWW.HTCBV.COM
 POSTBUS 35, 2750 AA MOERKAPELLE FAX.: 079-5933311 info@htcbv.com

Client: Xentry lowerdriven

Project: Xentry lowerdriven

Location:

Correspondent on location:

Phone number on location:

Rev	Date:	By:	Chkd:
A	0 04-03-08	MS	HW
B			
C			
D			
E			
F			
G			

Dwg. nr.: G01

Scale:

By:

Orderrr.:

FOR APPROVAL

APPROVED

YES NO

SIGNATURE:

Attributes Xentry lower-driven:

- Powdercoating: Rot.2??
- Roll / base galvanized
- Panel surrounding: 0 K60x60
- Panel filling: K30x30
- Controls: 0 n/a
- X Standard settings (on request)

THIS DRAWING IS OWNED BY BRS SPEEDGATES B.V. AND MAY NOT BE REPRODUCED, COPIED IN WHOLE OR IN PART, OR GIVEN TO THIRD PARTIES FOR INSPECTION WITHOUT EXPRESS WRITTEN PERMISSION OF BRS SPEEDGATES B.V.